

PLANTA TIPICA
ESC. 1/20

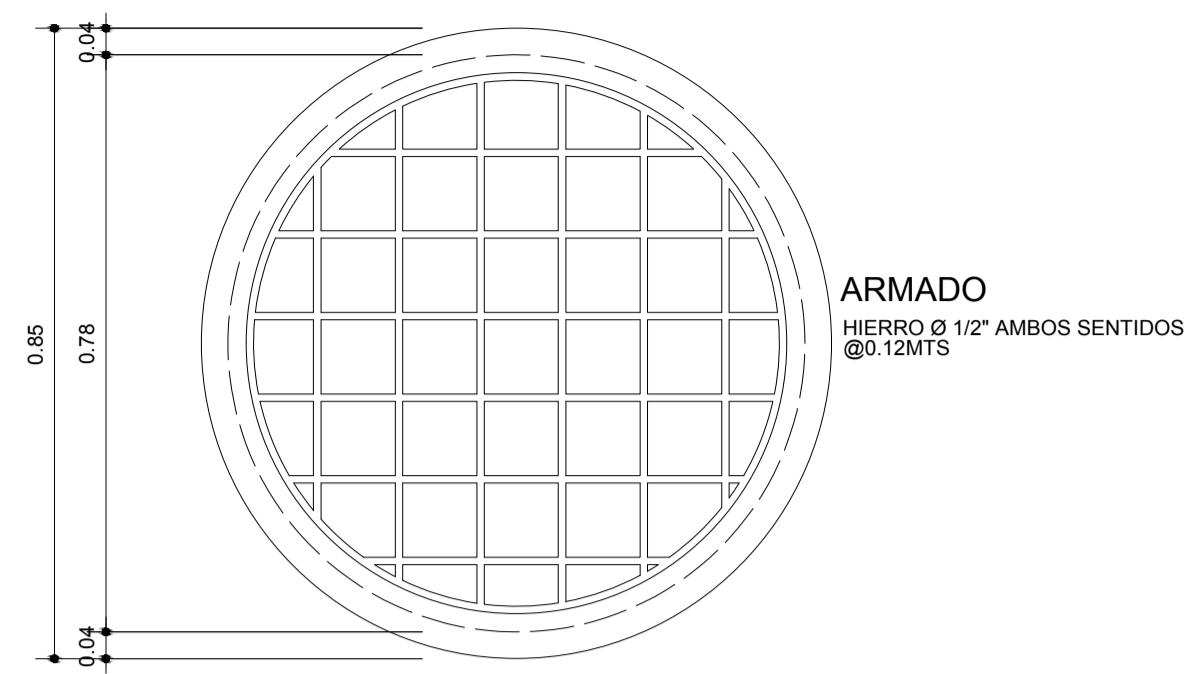

PLANTA TAPADERA
ESC. 1/10

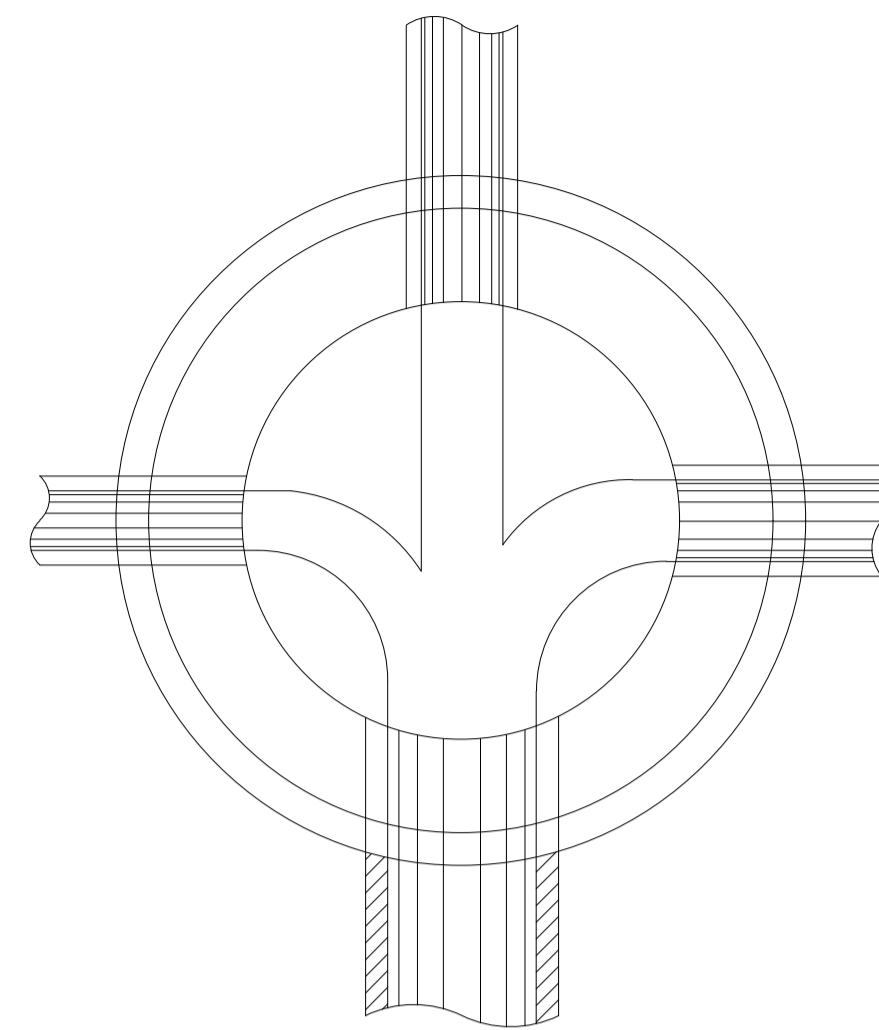

PLANTA F-F'
ESC. 1/20

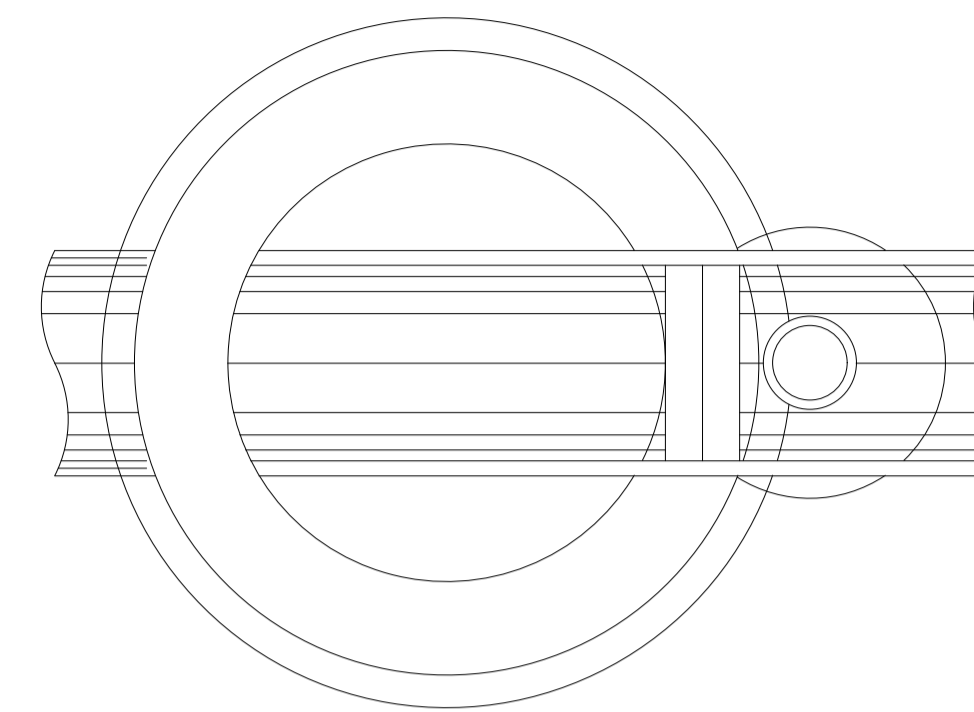

PLANTA G-G'
ESC. 1/20

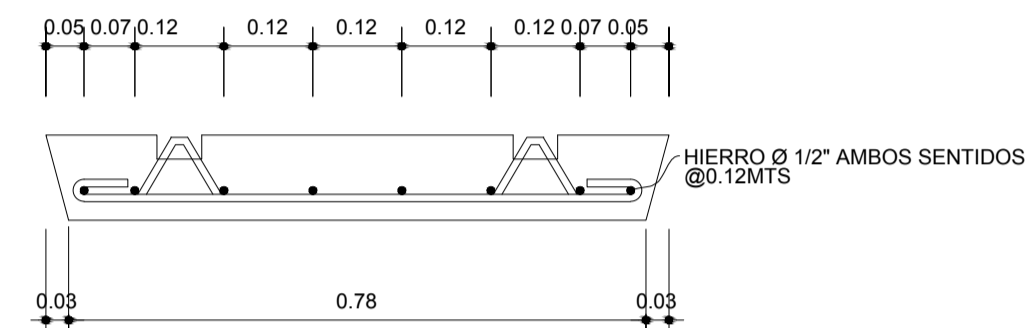
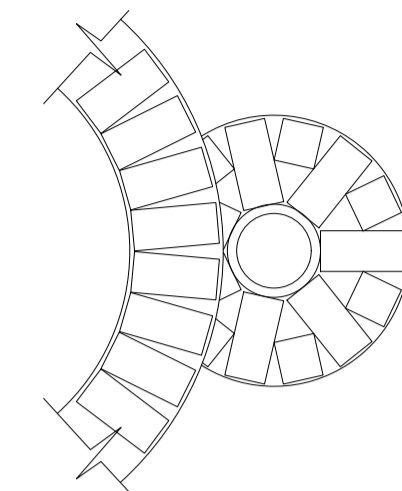

SENCIÓN C-C'
ESC. 1/10

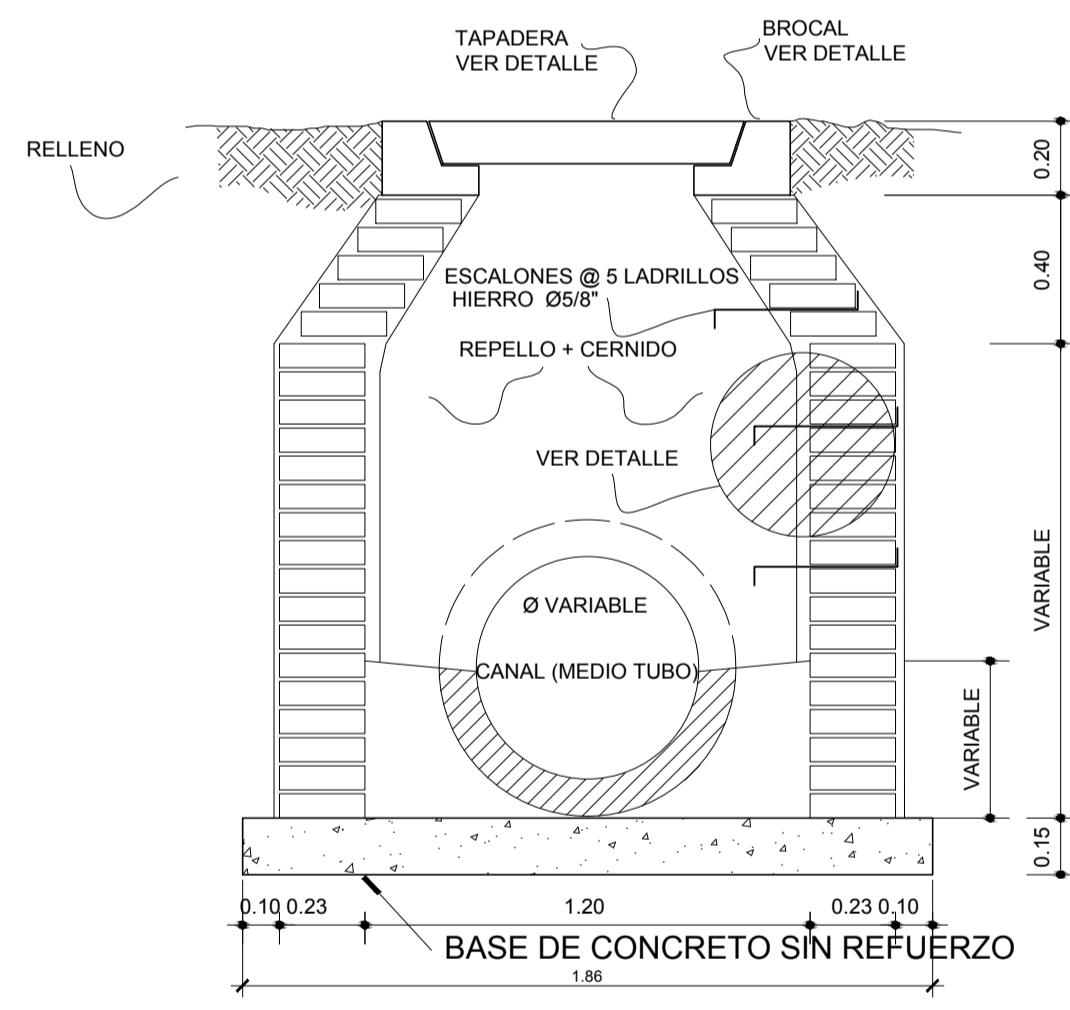

SECCION A
ESC. 1/20

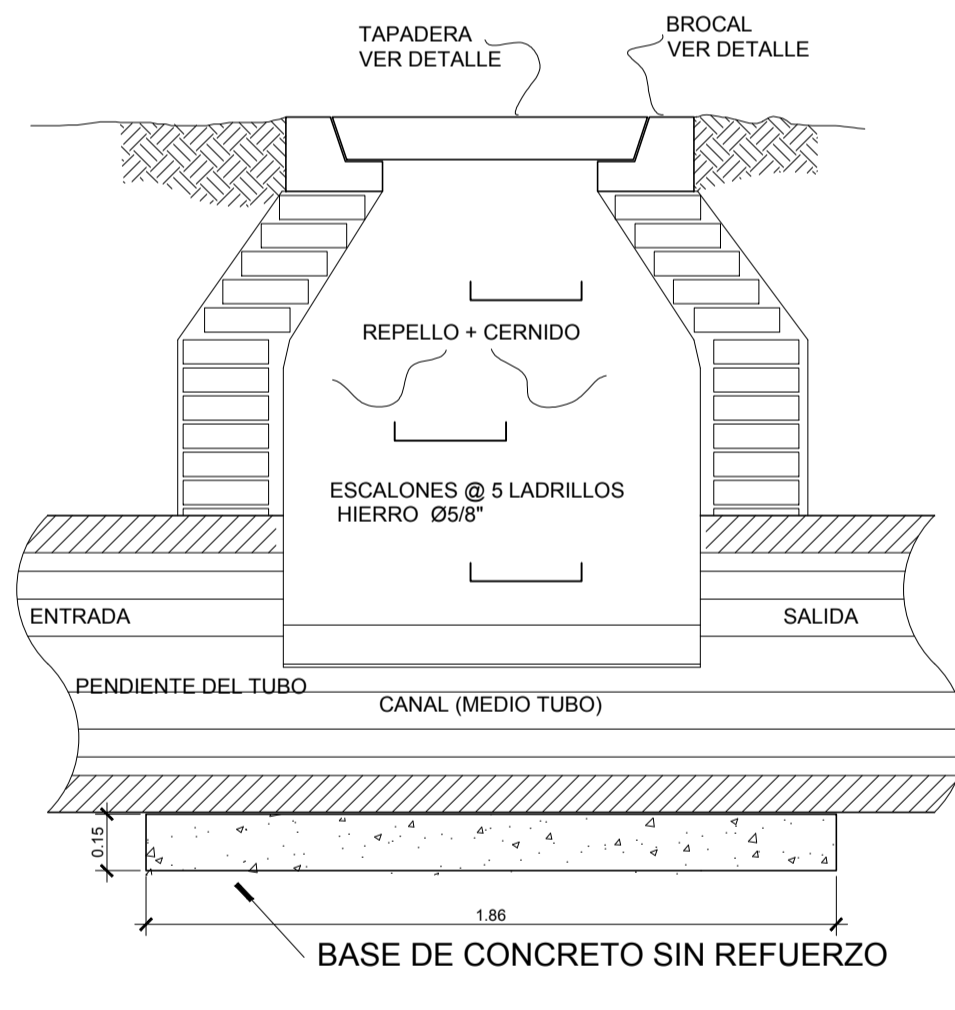

SECCION A
ESC. 1/20

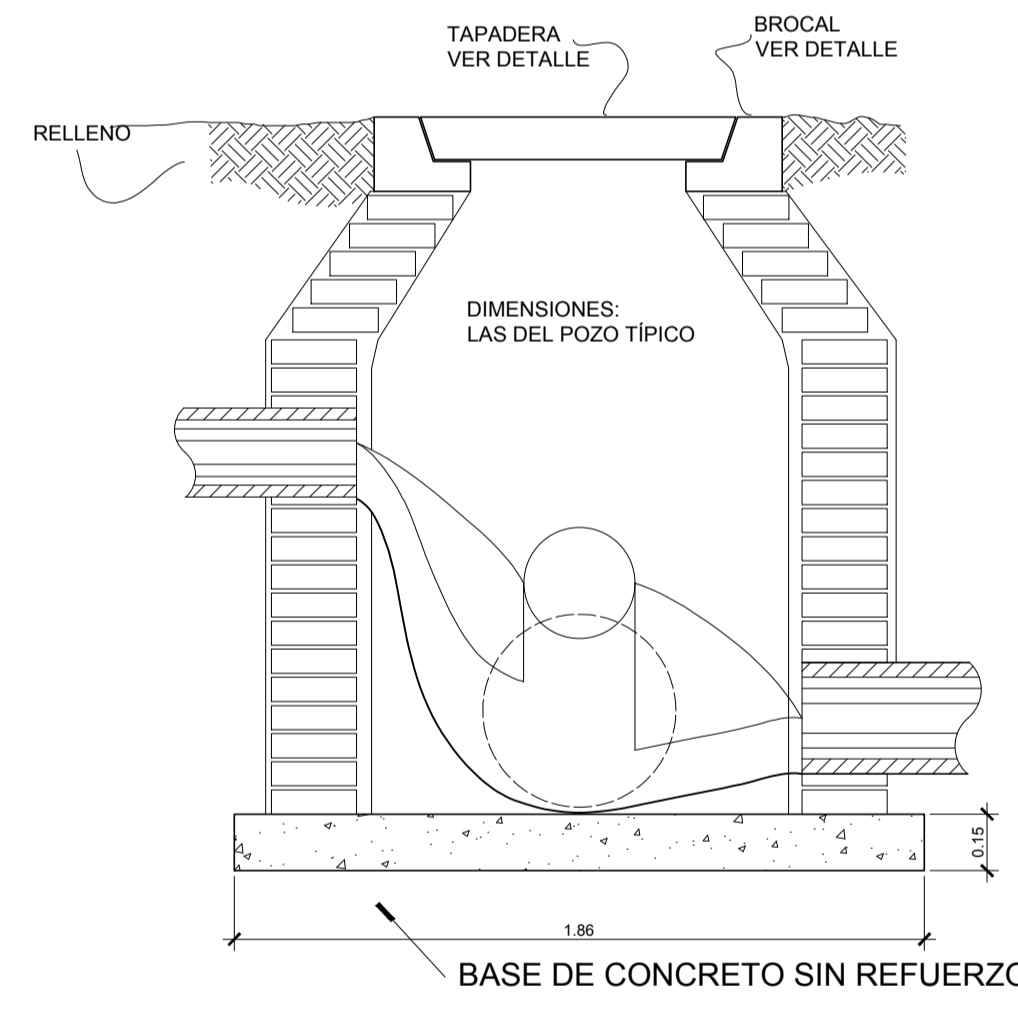

SECCION A
ESC. 1/20

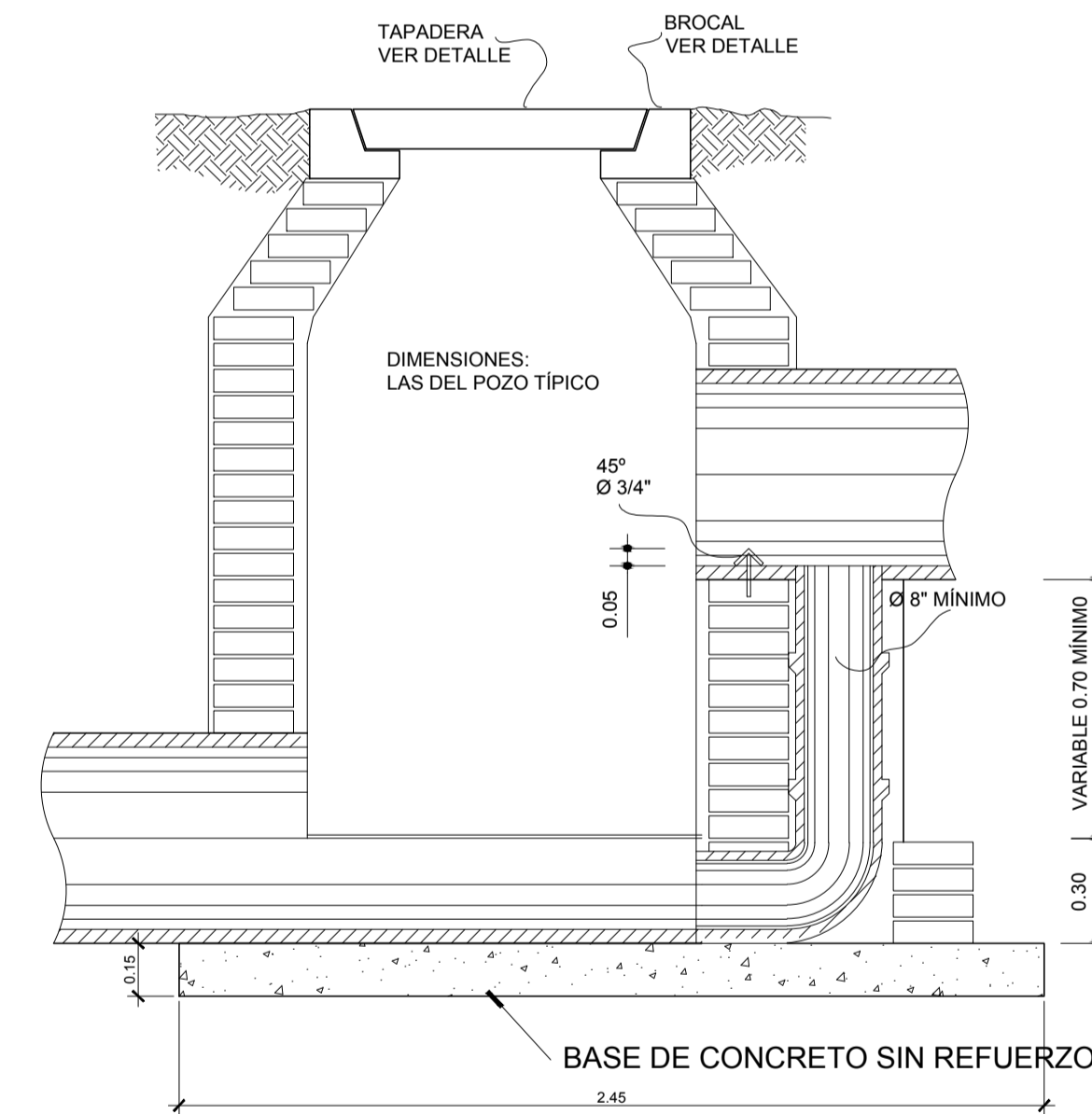

SECCION A
ESC. 1/20

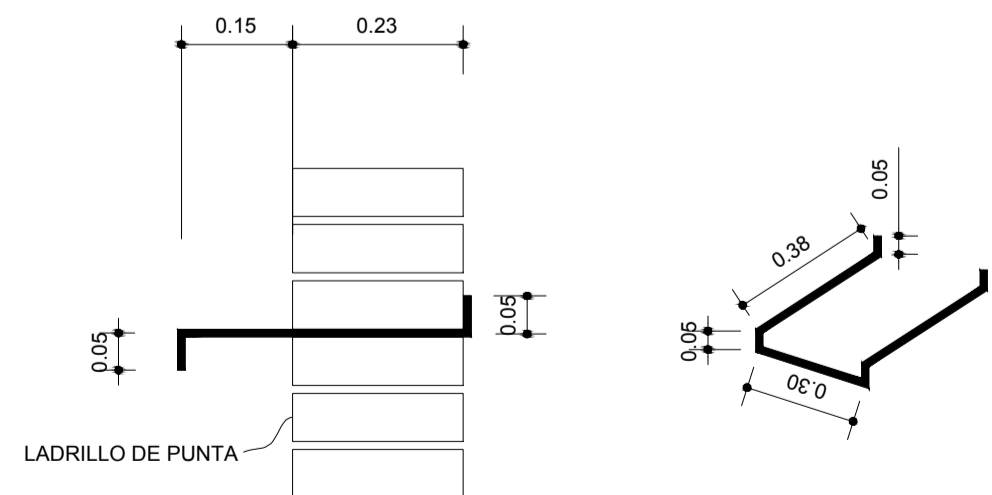
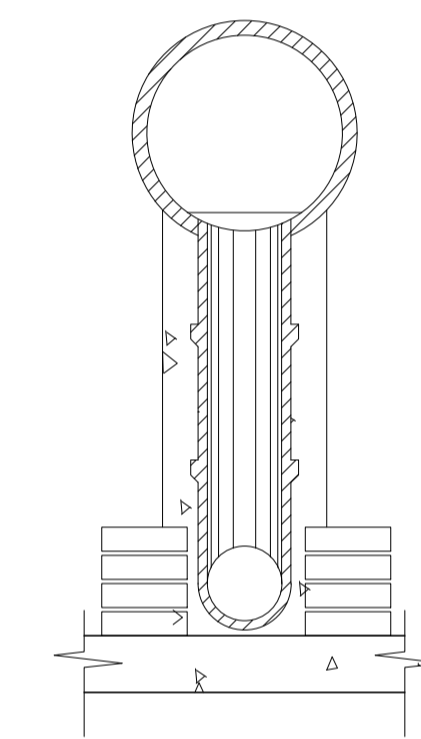

DETALLE DE ESCALÓN
ESC. 1/10

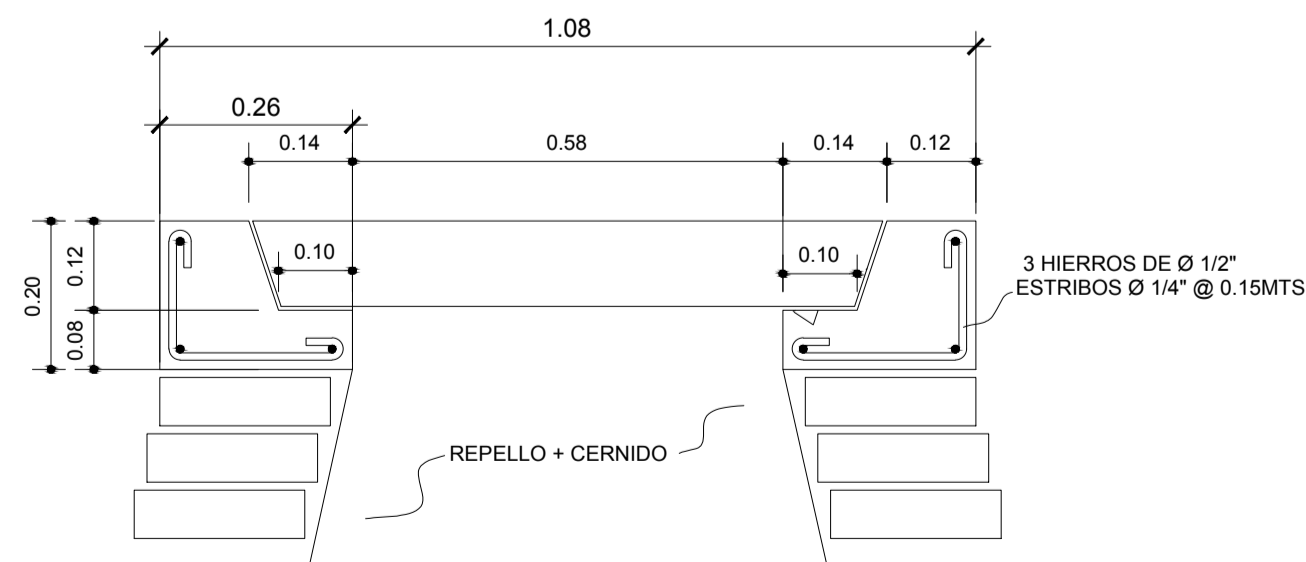

DETALLE DE TAPADERA Y BROCAL
ESC. 1/10

**MUNICIPALIDAD DE
SAN LORENZO
SUCHITEPEQUEZ**

PROYECTO
CONSTRUCCION SISTEMA DE ALCANTARILLADO + PLANTA DE
TRATAMIENTO DE AGUAS RESIDUALES DOMÉSTICAS, ALDEA NUEVO
AMANECER, SAN LORENZO, SUCHITEPEQUEZ.

REGIÓN VI SUROCCIDENTE DEPARTAMENTO SUCHITEPEQUEZ

MUNICIPIO SAN LORENZO

ALDEA NUEVO AMANECER

CONTIENE POZOS DE VISITA
DETALLES GENERALES

DISEÑO INGENIERO CIVIL CALCULÓ INGENIERO CIVIL

LEVANTÓ INGENIERO CIVIL DIBUJÓ INGENIERO CIVIL

FECHA ESCALA CÓDIGO HOJA No
MAYO 2019 INDICADA 07/22

Vo Bo. SELLO TIMBRE